

# QUICK CLEAN SANITARY FLUIDIZER KIT



## INSTALLS WITH STANDARD TRI-CLAMP EQUIPMENT FOR QUICK & EASY CLEANING

Sanitary Fluidizer Kit assemblies are ideal for installation in hoppers or bins that contain contaminant sensitive products and require frequent inspection and maintenance. Once installed, you can perform regular inspection and cleaning as required by any preventive maintenance program. All done from the outside, without confined space entry requirements, saving time and money.

### Design Features

- Used with Solimar's proprietary silicone disk (Silo Fluidizer) that will not plug, harden or crack
- Unique mounting kit utilizes a tri-clamp ferrule for easy installation and disassembly for inspection and/or cleaning
- Stem design reduces external thread exposure and allows for direct mounting of press-lock air fitting
- Stainless Steel and Food Grade UHMW plastic for 3A, FDA or any contaminant sensitive applications
- Available for use with both Standard and Mini Fluidizers
- Use with flat or conical hoppers

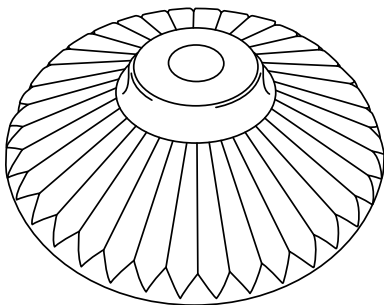

INSIST ON GENUINE  
SOLIMAR DISKS WITH  
THE TRADEMARKED  
RADIAL RIDGE DESIGN

## General Assembly Dimensions

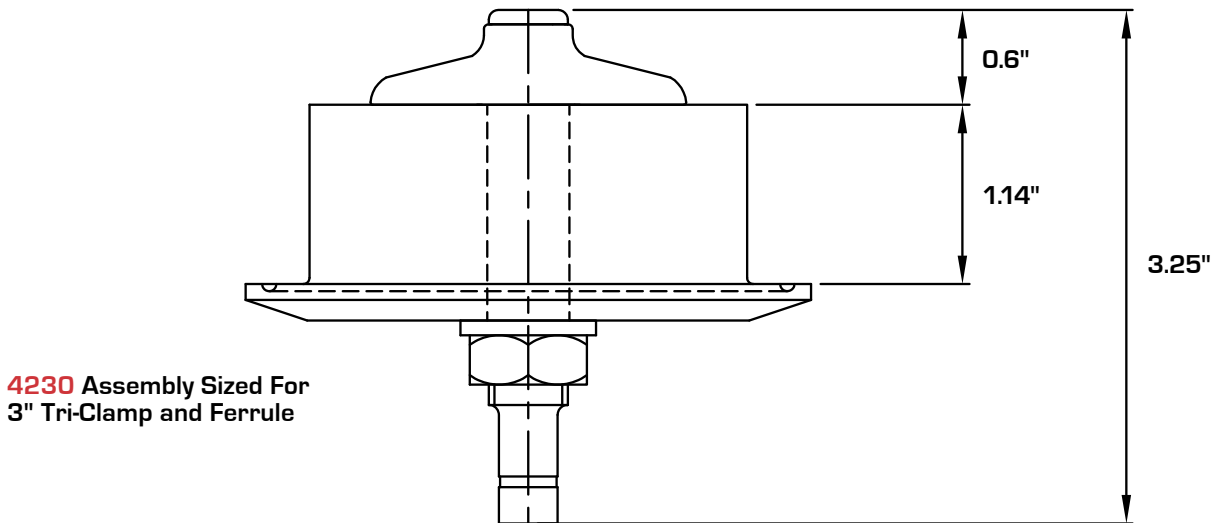
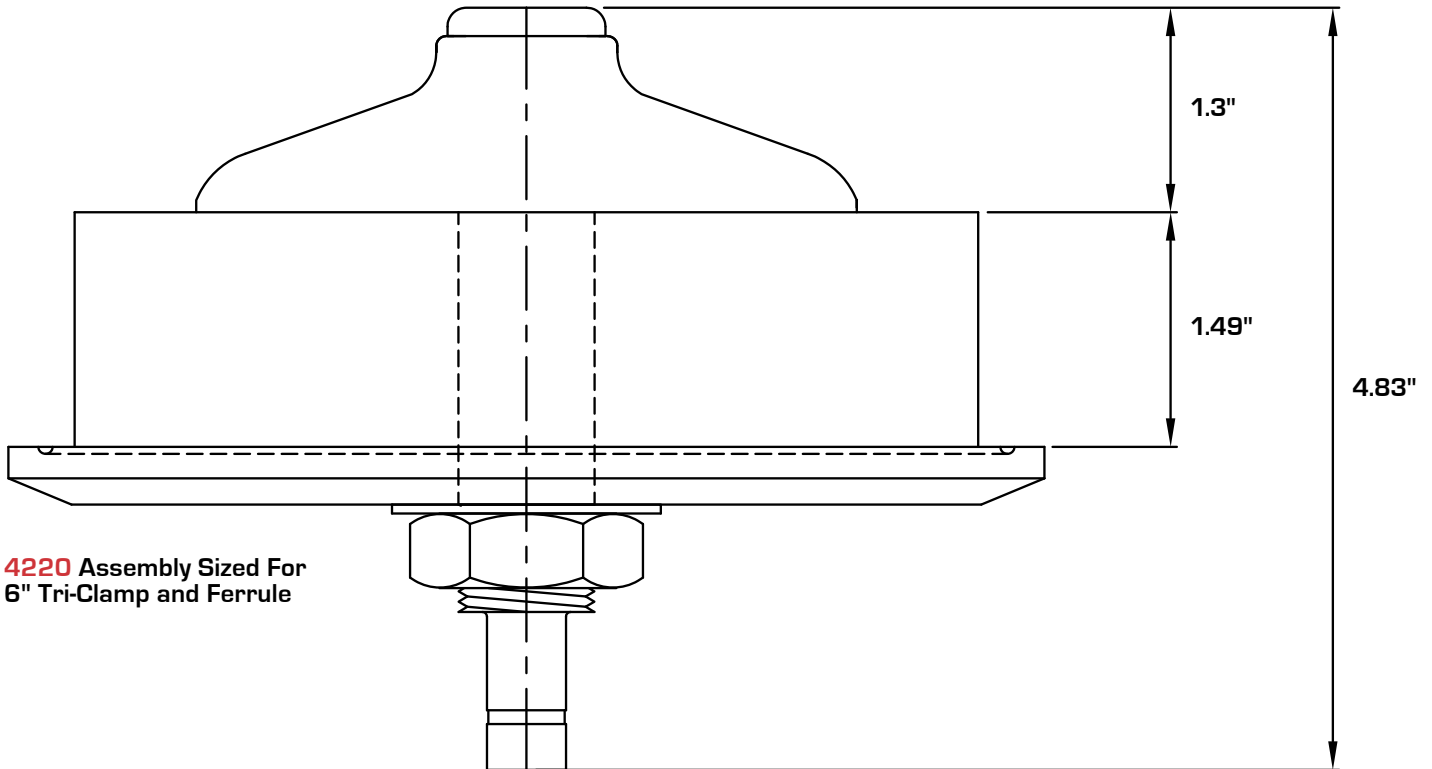

**ACCEPT  
NO SUBSTITUTES**

The Solimar Quick Clean Sanitary Fluidizer Kit is in a class by itself and is not interchangeable for reliability and durability with any other system. Accept no substitute. Specify Solimar Silo Fluidizers.