



Since 1985

Silo Fluidizer *with* Metal Detectable Disk



The latest in Solimar innovations addresses concerns from industries that require an extra level of safety.

Instances of Solimar fluidizer disks contaminating product are extremely rare, but disks that have been mechanically damaged during bin cleaning, by extreme air pressures or improper installation could potentially cause a problem. Designed to meet the stringent process requirements primarily of the dairy, pharmaceutical and food related industries; Solimar Pneumatics has developed the first Metal Detectable Fluidizer Disk. Your only choice when zero contamination is a must.



The grey disk, shown in the center, is the industries first silicone metal detectable disk.

Note: Due to the impregnated ferrous oxide, the Metal Detectable Disk is only available in grey.

Why Solimar Silo Fluidizers work where others have failed:

Aeration loosens up the product allowing it to flow easier. Minimum back pressure puts air energy where it is need the most - in the silo.

Directional Air Flow. The Fluidizer disk forces air to move along the bin wall freeing up product and assuring good cleanout.

Gentle Vibration keeps the product flowing without allowing it to compact or plug.

No Airline Plugging. Disk seals tightly against the silo wall and prevents airline plugging. Robust Design. The disk will not tear, pick up moisture & is unaffected by temperatures up to 350 F (170 C).

Material Compatible. Available in FDA approved silicone rubber in blue and white, FDA approved EPDM rubber in black or white, also Orange High Temp rubber, and now FDA approved grey Metal Detectable.

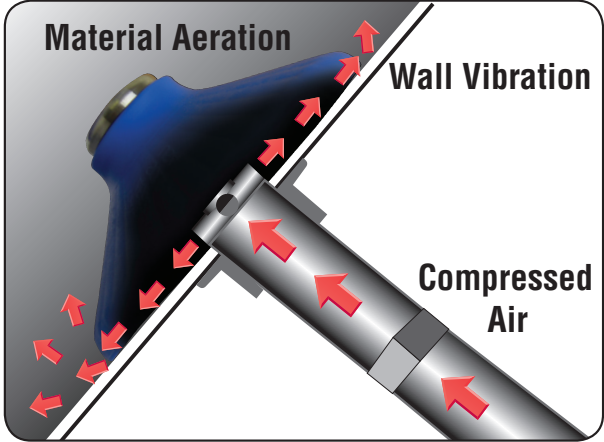

Hopper cutaway shows Fluidizer in use.

Silo Fluidizer Technical Data

Model	Disk Diameter	Stem	A	B	C	D	E	Airline Options
4305MD	4"	Stainless	1/4" NPT	1/2" NPT	7/8" (22mm)	1 3/16" (30 mm)	3" (76mm)	3/8" - 1/2" (10-13mm) Tubing

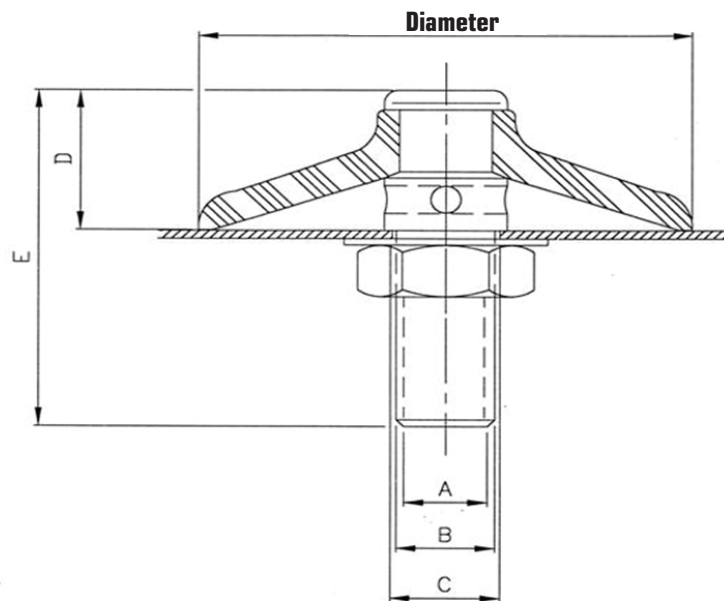

Model	AIRFLOW REQUIREMENTS
Standard 4305MD	Capacity 10 - 20 CFM @ 20 - 30 PSI (15 - 30m ³ /h @ 1 - 2 bar)

Engineering Assistance. Fax or e-mail a sketch or drawing of your chamber, along with a description of your bulk material and we will provide a recommended number and placement of fluidizers for your application the next day.

Versatility. Numerous combinations of stems, fittings and airlines to fit your application. Solimar Fluidizers models are available for use with high pressure/low volume compressed air or with low pressure/ high volume blower air.