

SOLIMAR

Since 1985

Fluidizer Control System

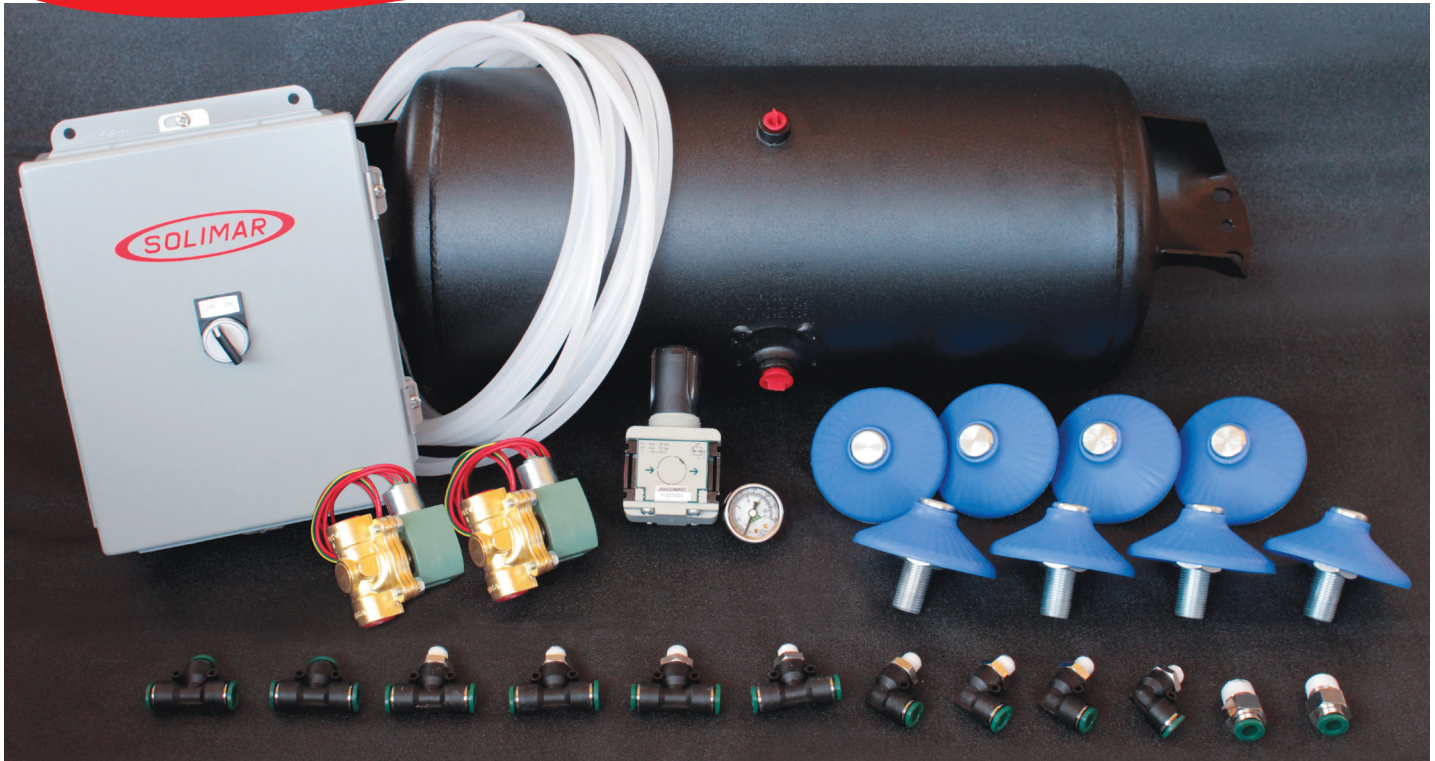

- ***Save on compressed air costs***
- ***Pulsate Aerators for optimum discharge***
- ***Alternate Aerator operation for highest performance***
- ***Controls up to 16 Aerators***

Share in our knowledge of dry bulk discharge techniques by installing a Controller to program the operation of your aeration system. Compressed air is a costly commodity. Operating your aerators only when they are needed and operating them in the proper sequence can provide a fast return on your investment. Pulsating aerators through the easy solid state controller provides more effective movement of powders while alternating aerators can assist in more complete discharge. Let our experts provide suggestions for your application. We have helped move more than 120 dry bulk materials. Let us help with yours.

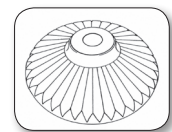

**Insist on genuine Solimar
disks with the trademarked
Radial Ridge Design.**

Solimar Pneumatics | Minneapolis, MN 55432 USA | 1.800.233.7109 | P: 763.574.1820

F: 763.574.1822 | email: solimar@solimarpne.com | www.solimarpneumatics.com

Solimar, Solimar-USA and the Radial Ridge Design are trademarks of Solimar Pneumatics

Fluidizer Control System

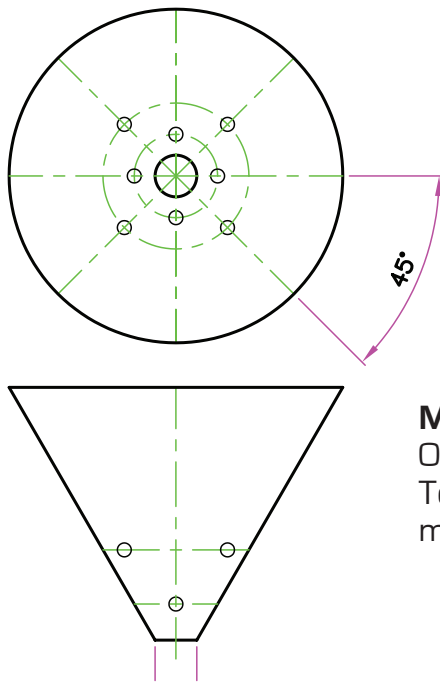

Effective placement of aerators depends on material type and volume requirements.

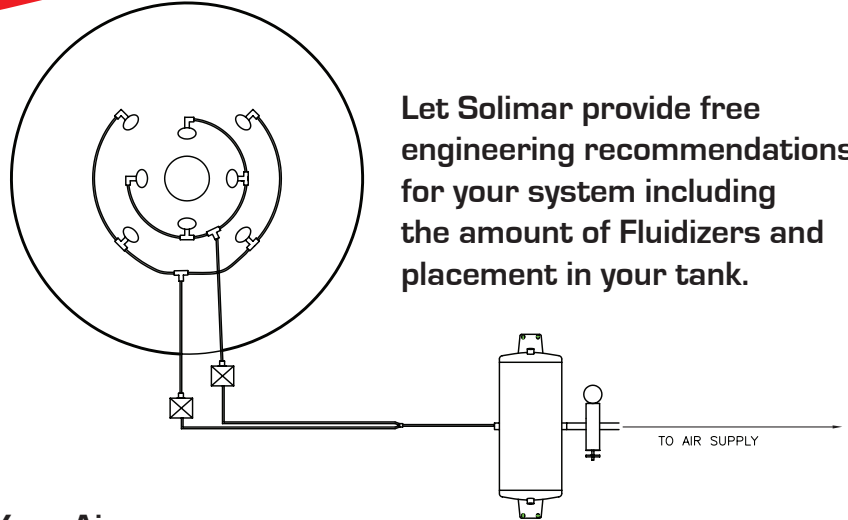

Let Solimar provide free engineering recommendations for your system including the amount of Fluidizers and placement in your tank.

Maximize Your Air

Only operate the Fluidizers while discharging material from the silo. To ensure balanced air distribution it is recommended to use an air manifold or operate no more than four Fluidizers together as shown.

SOLIMAR FLUIDIZER CONTROL SYSTEM PACKAGES INCLUDE:

- Timer Control Boards with Enclosure*
- Air Surge Tanks
- Solenoids
- Air Regulators
- Tubing
- Fittings
- Installation and Operating Instructions

*All enclosures are NEMA 4 unless otherwise requested.

Solimar Pneumatics is a leading designer and supplier of aeration systems and engineered components for the dry bulk material handling industry. **Solimar** services hundreds of customers worldwide with thousands of applications on silos, over-the-road truck trailers and lorries and intermodal containers.