

# Silo Fluidizer Mini Disk

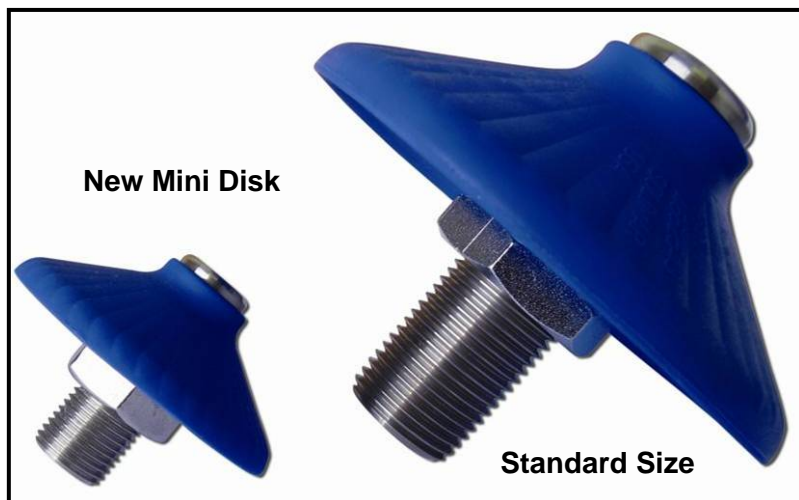

www.solimarpneumatics.com

## Mini Fluidizing Disk Keeps Material Moving in Areas with Tight Curvature



Solimar's New Mini Disk is Half the Size of our Standard Disk to Fit Tight Curvature Chambers

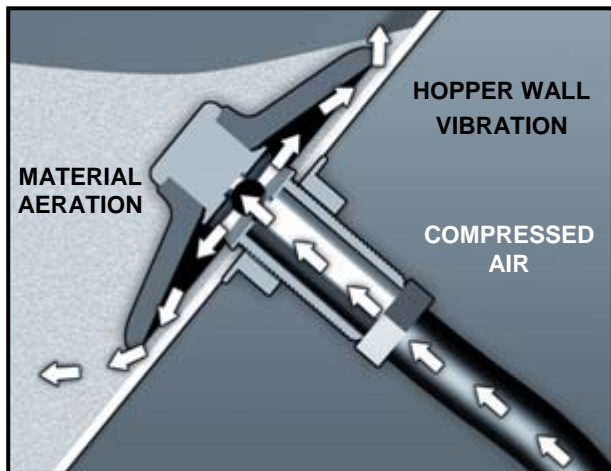

Hopper cutaway showing fluidizer action

Solimar's Mini Fluidizing Disk -- all the features of our standard disk to prevent bridging, rat holing and compacting in tight curvature situations where standard disks will not fit.

Perfect for:

- ✓ Tight Curvature Chambers --  
4" (100MM) diameter
- ✓ Chutes, Pipes, Small Hoppers
- ✓ Corner Hang-ups

**Aeration** loosens up the product allowing it to flow. Minimum back pressure puts air energy where it is needed the most – into the product chamber.

**Directional Air Flow.** Air is forced along the chamber wall, freeing up product and keeping it moving.

**Gentle Vibration** keeps the product flowing, preventing compaction or plugging.

**No Airline Plugging.** Seals tightly against the chamber wall and prevents airline plugging.

**Robust Design.** Will not tear, pick up moisture & is unaffected by temperatures up to 350° F (170° C).

**Material Compatible.** Silicone blue rubber is both food grade and FDA approved.

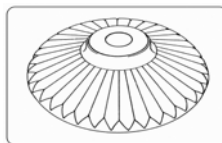

Insist on genuine Solimar disks with the trademarked Radial Ridge Design

Solimar Pneumatics

Minneapolis, MN 55432 USA

1 800 233.7109

Tel: 763 574.1820 / Fax: 763 574.1822

e-mail: solimar@solimarpne.com

# Mini Silo Fluidizer – Technical Data

Model	Disk Diameter	Stem	A	B	C	D	E	Airline Options
MINI 4804	2"	Stainless	1/8" NPT	NA	1/2" (13mm)	9/16" (14mm)	1-1/2" (38mm)	1/4" (6mm) Tubing
Standard 4304	4"	Stainless	1/4" NPT	1/2" NPT	7/8" (22mm)	1 3/16" (30mm)	3" (76mm)	3/8" – 1/2" (10 - 13mm) Tubing

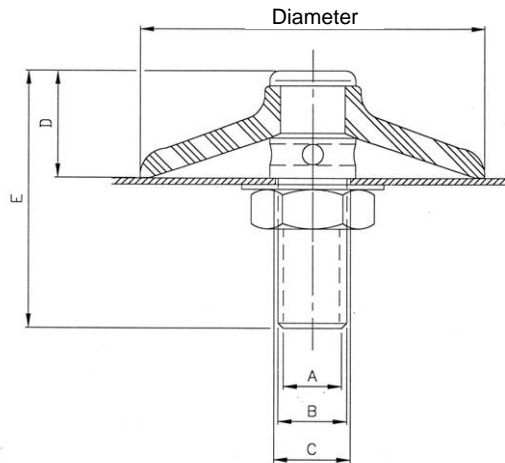

Model	AIRFLOW REQUIREMENTS
MINI 4804	Capacity 2 – 3 CFM @ 20 – 30 PSI (3.5 – 5m <sup>3</sup> /h @ 1-2 bar)
Standard 4304	Capacity 10 – 20 CFM @ 20 – 30 PSI (15 – 30m <sup>3</sup> /h @ 1-2 bar)

**Engineering Assistance.** Fax or e-mail a sketch or drawing of your chamber, along with a description of your bulk material and we will provide a recommended number and placement of fluidizers for your application the next day.

**Versatility.** Numerous combinations of stems, fittings and airlines to fit your application. Solimar Fluidizers models are available for use with high pressure/low volume compressed air or with low pressure/ high volume blower air.

08/08

1 800 233.7109

Tel: 763 574.1820 / Fax: 763 574.1822

e-mail: [solimar@solimarpne.com](mailto:solimar@solimarpne.com)