



www.solimarpneumatics.com

Check Valve

RELIABILITY WITH SIMPLICITY



Solimar Pneumatic's **3" Check Valve** is engineered to meet or exceed all requirements for unloading dry bulk products. Solimar's Check Valve offers significant cost and quality improvements over the older style valves to assure smooth and positive operation.

LIGHTWEIGHT ALUMINUM – ONLY 3 lbs.

MULTI-POSITIONAL – MOUNT AT ANY ANGLE

STAINLESS INTERNAL COMPONENTS

FDA APPROVED SILICONE RUBBER SEALING SERVICES

POSITIVE SPRING VALVE CLOSURE

EXCELLENT AIR FLOW

Solimar Pneumatics

Minneapolis, MN 55432 USA

1 800 233.7109

Tel: 763 574.1820 / Fax: 763 574.1822

e-mail: solimar@solimarpne.com

Check Valve

Fits all industry standard trailers and is available for both new or retro-fitted installation

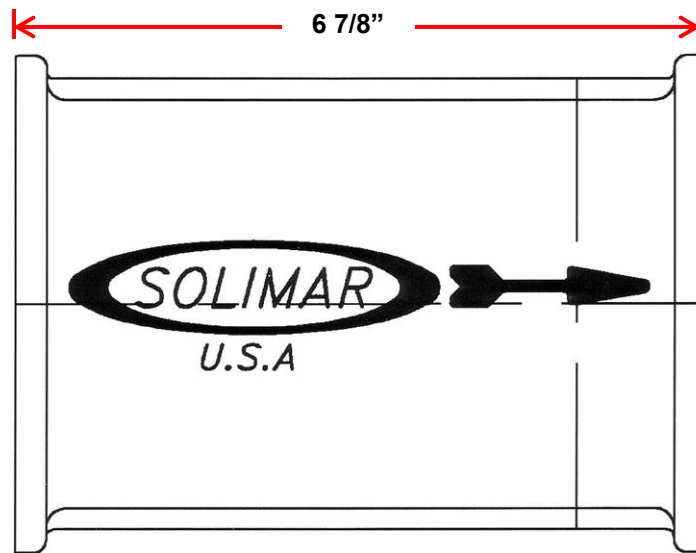
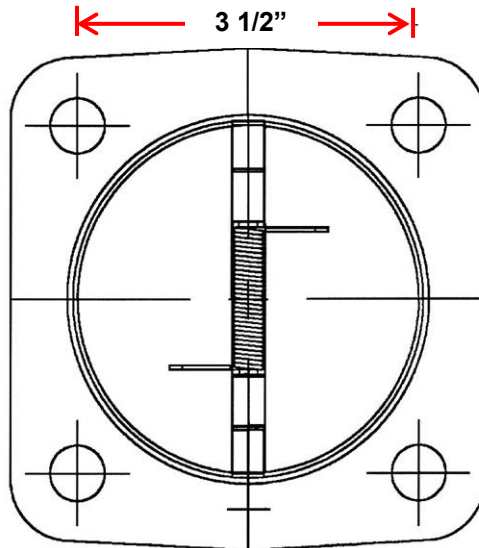

Solimar Pneumatics is a leading designer and supplier of aeration systems and engineered components for the dry bulk material handling industry. **Solimar** services hundreds of customers worldwide with thousands of applications on over-the-road truck trailers and lorries and intermodal containers.

A Tradition of Leadership - Solimar has over 40 years of experience in pneumatic systems and components for dry bulk handling. Solimar provides engineered solutions to the most difficult material flow problems.

08/08



1 800 233.7109

Tel: 763 574.1820 / Fax: 763 574.1822

e-mail: solimar@solimarpne.com